

iFLUE

MULTI FUEL CHIMNEY SYSTEM



CE
0086

SPECFLUE

Introduction

iFlue has been specifically designed to meet the requirements of multi-functional applications for a variety of fuels. The system provides an economical and robust twin wall insulated stainless steel chimney system offering high material specification, design, manufacturing quality, thermal performance and ease of installation. iFlue is suitable for negative draught conditions where the maximum continuous flue gas temperature does not exceed 450°C (550°C Intermittent) and is soot fire rated at 1000°C. Where used on wet or applications requiring a positive pressure capability, such as condensing appliances, the iFlue product can be fitted with an optional elastomer seal. The elastomer seals are fitted at each joint and provide a positive pressure capability of up to 200Pa at a maximum flue gas temperature of 200°C, offering full condensate resistance.

Description

iFlue is available in six internal diameters, ranging from 100mm to 250mm, and consists of Lengths, Fittings and Support components. Each chimney element is fabricated with a fully welded 316L (1.4404:X2CrNiMo 17-12-2) stainless steel inner liner and a grade 304 (1.4301:X5CrNi 18-10) outer case. The 25mm annulus between the two wall is insulated with a high thermal performance auger injected mineral fibre to a mean density of 250Kg/m³. All flue gas carrying components are joined together with a simple push fit joint with the male end providing a slight taper to ensure ease of installation, while the 30mm of engagement offers a strong structural joint. The joint must then be finished with a Locking Band, which is included with the component.

Application

iFlue is designed to be used both internally and externally as a fully supported structure, and must be installed in accordance with National and Local Building Regulations and Standards. Where iFlue is being used on a wet system such as a chimney system serving a high efficiency condensing boiler, adequate provision must be made for the removal of condensates from the system. To encourage adequate drainage of condensates through the system, no sections of the system should run at an angle of less than 5° from the horizontal. The range includes specific components including a Condensate Collector, 95° Tee and 85° Elbow, all to enable the chimney system to be installed so that condensation will run back through the system to suitable drainage points.

Support

The system MUST only be supported by components within the product range. The maximum length of vertical run which can be supported by any component is defined in the installation instructions.

Approvals

The iFlue product is manufactured and conforms to BS EN 1856-1 and tested to the requirements of BS EN 1859 to the performance designation detailed in Table A. The Product is CE Marked under certificate No. 0086-CPD-496040.

Fire Resistance

The product has also been assessed by the Loss Prevention Council for fire resistance. A Fire Resistance of two hours can be achieved in accordance with the stability and integrity criteria of BS 476: Part 20 for duct type B. The Intumescent Ventilated Firestop components have also been tested and have achieved a fire resistance of 51 minutes in accordance with the stability and integrity criteria of BS 476: Part 20, report number 175995. The fire resistance test assessed the performance of the components through a typical standard floor construction representative of the intended application and installation.

Technical Support

As leading suppliers with over 30 years experience, Specflue have a wealth of technical knowledge and understanding of chimney design. Using the latest CAD and flow modelling software, Specflue can offer fast analysis of conceptual chimney designs to the latest European Standards. Specflue can also offer assistance with other areas of legislation regarding Building Regulations, Clean Air Act and Installation Standards covering chimney systems. Where applicable, calculations to the Clean Air Act Memorandum can also be undertaken. In all cases full technical details and drawings must be submitted with requirement to Specflue Technical Support.

As iFlue is manufactured in the UK, Specflue are ideally placed to offer rapid production of bespoke and custom components to meet the demands of today's installation requirements. Whether it is a special angled elbow or a complete multi-inlet manifold, Specflue is your key strategic partner for professional, high quality engineered solutions.

Table A

iFlue Product Designations To BS EN 1856-1							
iFlue	EN1856-1	T450	N1	D	V2	L50050	G(50)
iFlue+	EN1856-1	T200	P1	W	V2	L50050	O(50)

Standard ———>

Temperature class ———>

Pressure class ———>

Condensate resistance
D=Dry W=Wet ———>

Corrosion Class ———>

Material specification
Liner: Grade 316L
Thickness: 0.5mm ———>

Sootfire resistance
G=Yes
O=No
Distance to combustible material = 50mm ———>

Note: For Adjustable Lengths the distance to combustible materials should be increased to 300mm

iFlue+ = With elastomer seal

Joint Detail

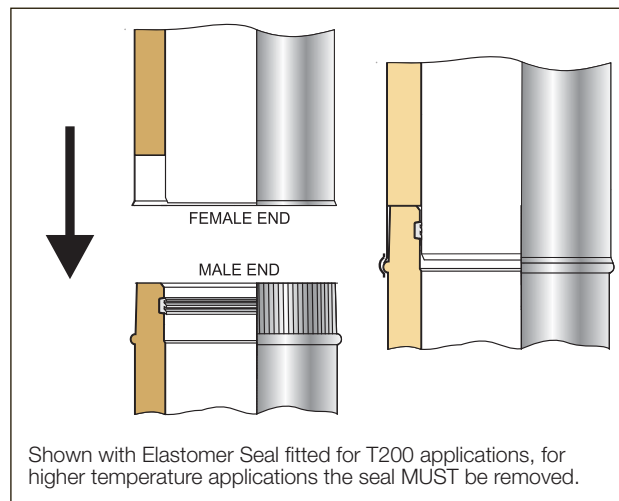

Dimensions Used In Publication

Unless otherwise stated, all dimensions used within this publication are metric (mm, metres, Kg and degrees).

Product Information

Joint Assembly

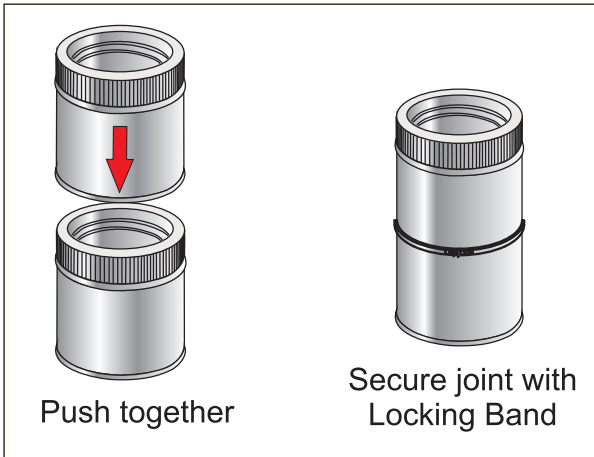

Product Weights

The table below gives the average product weight per metre based on a mean insulation density of 250Kg/m³.

Internal Diameter (mm)	Weight In Kg					
mm	100	130	150	180	200	250
Kg	2.28	2.82	3.18	3.72	4.08	4.98

Diameter Dimensions

Internal Diameter	Outside Diameter	Cross-Sectional Area
100mm	151mm	7855mm ²
130mm	181mm	13274mm ²
150mm	201mm	17673mm ²
180mm	231mm	25450mm ²
200mm	251mm	31420mm ²
250mm	300mm	49093mm ²

A Typical Installation

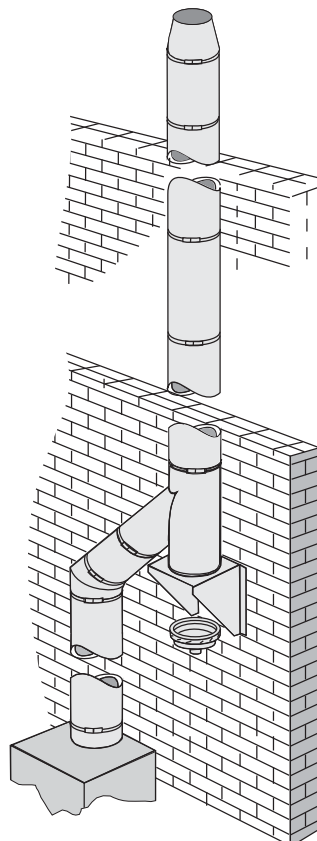

System Components

Starting Components / Adaptors

Prima+ Adaptors

This component is designed to facilitate connection from Prima+ to the iFlue chimney system.

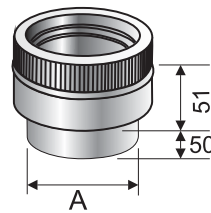

Flue Size	A (mm)	Code
100mm	100	0404094
130mm	125	0405094
150mm	150	0406094
180mm	180	0407094
200mm	200	0408094
250mm	250	0410094

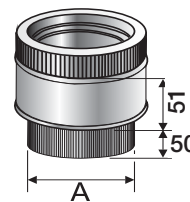

Adaptor from Vit to iFlue

This component is designed to facilitate connection from Vitreous pipe to the iFlue chimney system.

Flue Size	A (mm)	Code
100mm	95	0404093
130mm	120	0405093
150mm	145	0406093
180mm	170	0407093
200mm	195	0408093
250mm	249	0410093

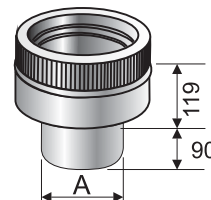

Increasing Adaptor

Used to increase the connecting pipe size by one diameter.

Flue Size	A (mm)	Code
130mm	95	0405097
150mm	120	0406097
180mm	145	0407097
200mm	170	0408097
250mm	195	0410097

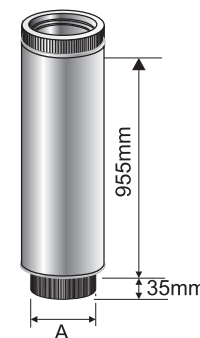

Twin Wall Stove Connector Length

This component can be used directly off the stove and consists of a durable 1mm 316L liner complete with a crimped end to facilitate connection directly to the stove.

Flue Size	A (mm)	Code
100mm	96	0404004
130mm	126	0405004
150mm	146	0406004
180mm	176	0407004
200mm	196	0408004
250mm	246	0410004

System Components

Starter Length

The Starter Length offers an aesthetic transition between the connecting flue pipe and the iFlue chimney system.

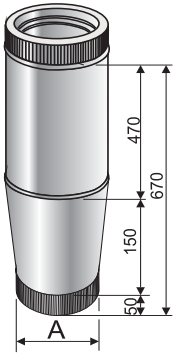

Flue Size	A (mm)	Code
100mm	98	0404101
130mm	128	0405101
150mm	148	0406101
180mm	178	0407101
200mm	198	0408101

Adaptor iFlue to SW

This component is designed to facilitate connection from iFlue to SW.

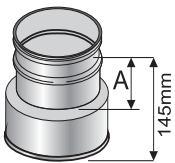

Flue Size	A (mm)	Code
100mm	63	0404063
130mm	63	0405063
150mm	63	0406063
180mm	42	0407063
200mm	42	0408063
250mm	42	0410063

Adaptor to Flex

This component is designed to facilitate connection from the iFlue chimney system to a flexible chimney liner.

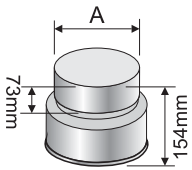

Flue Size	A (mm)	Code
100mm	108	0404090
130mm	138	0405090
150mm	158	0406090
180mm	188	0407090
200mm	208	0408090
250mm	258	0410090

Lengths & Ancillaries

Straight Lengths

Fixed straight lengths are available in four installed lengths, 115mm, 240mm, 490mm and 990mm. The actual component length is 30mm greater due to the height of the crimp.

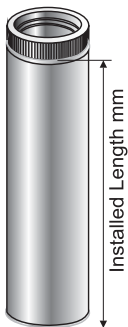

Flue Size	Installed Length (mm)			
	115	240	490	990
100mm	0404006	0404012	0404005	0404002
130mm	0405006	0405012	0405005	0405002
150mm	0406006	0406012	0406005	0406002
180mm	0407006	0407012	0407005	0407002
200mm	0408006	0408012	0408005	0408002
250mm	0410006	0410012	0410005	0410002

Inspection Length

This component is designed to facilitate inspection and cleaning of the chimney system. An additional inner and outer door seal can also be provided for applications where the chimney requires condensate and pressure resistance and where the flue gas temperature is below 200°C. See page 18 for load bearing data.

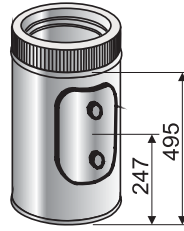

Flue Size	Code
100mm	0404013
130mm	0405013
150mm	0406013
180mm	0407013
200mm	0408013
250mm	0410013

Adjustable Length

The Adjustable Length offers a degree of flexibility when standard length dimensions are not suitable. Adjustable Lengths are available in three sizes:

- Short (160mm - 230mm)
- Medium (285mm-400mm)
- Long (375mm - 570mm)

These dimensions represent the minimum and maximum adjustment of the component.

All Adjustable Lengths are supplied with separate insulation material for insertion into the annulus once the installed length has been determined.

Due to the on site installation of the insulation, these components should always be located at least 300mm from any combustible material.

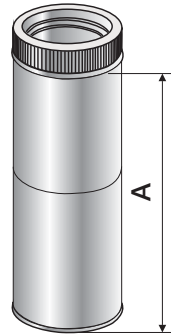

Note: For applications that require condensation and pressure resistance, 2 off Seals are required and must be ordered separately. Adjustable Lengths are not load bearing, always use a support component directly above this component.

Flue Size	Short (A)	Medium (A)	Long (A)
	160-230mm	285-400mm	375-570mm
100mm	0404018	0404016	0404015
130mm	0405018	0405016	0405015
150mm	0406018	0406016	0406015
180mm	0407018	0407016	0407015
200mm	0420018	0408016	0408015
250mm	0410018	0410016	0410015

Locking Band

A Locking Band is supplied complete with all components except bottom adaptors. Additional Locking Bands can be ordered separately if required.



Flue Size	Code
100mm	0404086
130mm	0405086
150mm	0406086
180mm	0407086
200mm	0408086
250mm	0410086

Lengths & Ancillaries Con't

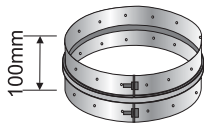

Structural Locking Band

A Structural locking Band can be used to increase the available free-standing height from 1.5 metres to 3.0 metres when installed in accordance with the installation instructions. Width of band: 100mm.

Flue Size	Code
100mm	0404086A
130mm	0405086A
150mm	0406086A
180mm	0407086A
200mm	0408086A
250mm	0410086A

Elastomer Seal

Where iFlue is used for wet or pressure applications, a seal must be fitted to each joint and must be ordered separately. When using Adjustable Lengths, two seals need to be ordered. Max. pressure capability is 200Pa at temperature of 200°C.

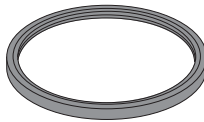

Flue Size	Code
100mm	0404831
130mm	0405831
150mm	0406831
180mm	0407831
200mm	0408831
250mm	0410831



Seal Lubricant (P1 / W)

Lubricant must be applied around the circumference of the fitted seal to provide a lubricated interface between the seal and the liner when the product is used for positive pressure and wet applications.

Seal Lubricant	0405833
----------------	---------

Tees & Elbows

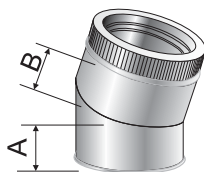

15° Elbow

Provides a 15° change of direction from the vertical.

Flue Size	A (mm)	B (mm)	Code
100mm	91	97	0404025
130mm	98	104	0405025
150mm	102	108	0406025
180mm	112	112	0407025
200mm	123	118	0408025
250mm	123	129	0410025

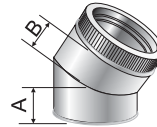

30° Elbow

Provides a 30° change of direction from the vertical.

Flue Size	A (mm)	B (mm)	Code
100mm	91	97	0404024
130mm	98	104	0405024
150mm	102	108	0406024
180mm	112	112	0407024
200mm	123	118	0408024
250mm	123	129	0410024

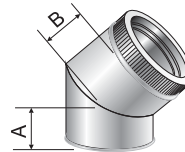

40° Elbow

Provides a 40° change of direction from the vertical. For use on wet systems to aid the flow of condensates back through the system where the flue run is installed at 5° minimum incline to the horizontal.

Flue Size	A (mm)	B (mm)	Code
100mm	91	97	0404023
130mm	98	104	0405023
150mm	102	108	0406023
180mm	112	112	0407023
200mm	123	118	0408023
250mm	123	129	0410023

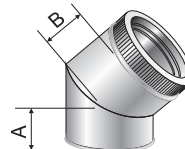

45° Elbow

Provides a 45° change of direction from the vertical.

Flue Size	A (mm)	B (mm)	Code
100mm	91	97	0404022
130mm	98	104	0405022
150mm	102	108	0406022
180mm	112	112	0407022
200mm	123	118	0408022
250mm	123	129	0410022

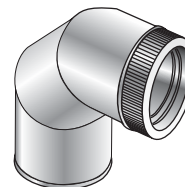

90° Elbow

Provides a 90° change of direction from the vertical.

Flue Size	Code
100mm	0404021
130mm	0405021
150mm	0406021
180mm	0407021
200mm	0408021
250mm	0410021

Tees & Elbows Con't

85° Elbow

Provides a 85° change of direction from the vertical. For use on wet systems to aid the flow of condensates back through the system where the flue run is installed at 5° minimum incline to the horizontal.

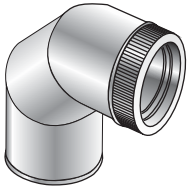

Flue Size	Code
100mm	0404020
130mm	0405020
150mm	0406020
180mm	0407020
200mm	0408020
250mm	0410020

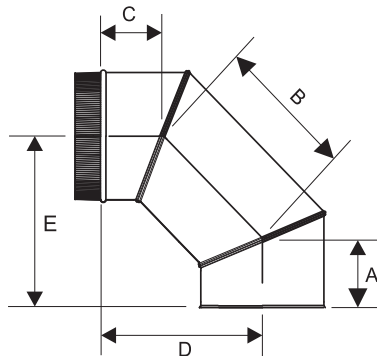

Dimensions for 90° and 85° Elbows

Flue Size	A	B	C	D (90°)	D (85°)	E
100mm	91	126	125	180	192	184
130mm	98	136	132	193	207	198
150mm	102	144	136	204	217	208
180mm	108	156	142	219	233	222
200mm	112	165	146	229	244	233
250mm	123	185	157	254	270	258

All dimensions in mm.

90° Tee

Used at the base of a vertical chimney, or for horizontal header configurations.

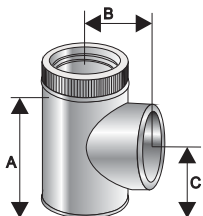

Flue Size	A	B	C	Code
100mm	330	140	180	0404043
130mm	360	155	195	0405043
150mm	380	165	205	0406043
180mm	410	180	220	0407043
200mm	432	190	230	0408043
250mm	482	215	255	0410043

All dimensions in mm.

95° Tee

Used at the base of a vertical chimney, or for horizontal header configurations. The 95° Tee is designed to aid the flow of condensates by offering a 5° incline to the connecting flue pipe.

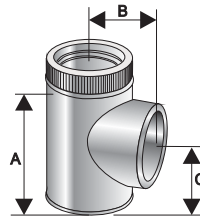

Flue Size	A	B	C	Code
100mm	330	140	180	0404042
130mm	360	155	195	0405042
150mm	380	165	205	0406042
180mm	410	180	220	0407042
200mm	432	190	230	0408042
250mm	482	215	255	0410042

All dimensions in mm.

135° Tee

Used at the base of a vertical chimney or to facilitate a smooth transition to the vertical when used with a 45° Elbow on the branch.

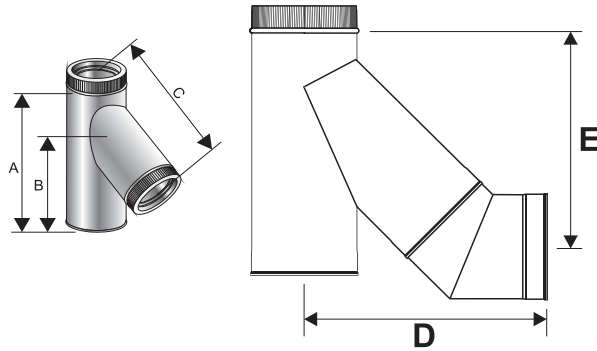

Flue Size	A	B	C	D	E	Code
100mm	395	325	325	378	553	0404044
130mm	410	340	340	401	476	0405044
150mm	445	375	375	433	508	0406044
180mm	510	420	420	473	568	0407044
200mm	540	450	450	503	598	0408044
250mm	620	520	520	471	674	0410044

All dimensions in mm.

Refer to page 18 for load bearing information for tee components.

Tee Plug

Used to close off the branch or base of a tee.

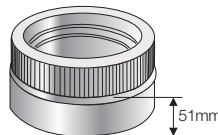

Flue Size	Code
100mm	0404091
130mm	0405091
150mm	0406091
180mm	0407091
200mm	0408091
250mm	0410091

System Components

Condensate Collector

Used at the base of a vertical chimney to facilitate the drainage of condensate from the system. Fitted with a stainless steel 1" BSP connection.

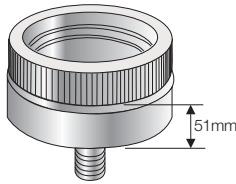

Flue Size	Code
100mm	0404532
130mm	0405532
150mm	0406532
180mm	0407532
200mm	0408532
250mm	0410532

Floor Penetration Components

Gas & Oil Fired Appliances With Flue Gas Temperatures Below 250°C (<T250)

The following components **MUST** be used on gas and oil fired appliances where the manufacturers declared flue gas temperature is below 250°C and / or where the chimney passes through a non-combustible floor.

Ceiling Support

Provides a 50mm air gap clearance to a penetrated floor or ceiling and is only used where iFlue penetrates a non-combustible floor, and / or services an oil or gas fired appliance where the flue gas temperatures do not exceed 250°C. The Ceiling Support can vertically support up to 6 Mtrs of product.

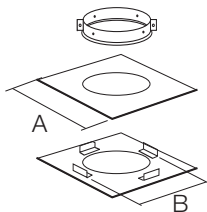

Dimensions A & B are square

Flue Size	A (mm)	B (mm)	Code
100mm	300	250	0404027
130mm	330	280	0405027
150mm	355	305	0406027
180mm	381	331	0407027
200mm	406	356	0408027
250mm	457	407	0410027

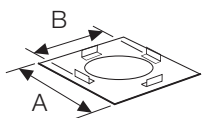

Dimensions A & B are square

Firestop Spacer

Used to provide location, fire and dust stopping where the iFlue passes through a non-combustible floor and / or serves a gas or oil fired appliance where the flue gas temperatures do not exceed 250°C. This component is not load bearing.

Flue Size	A (mm)	B (mm)	Code
100mm	300	250	0404087
130mm	330	280	0405087
150mm	355	305	0406087
180mm	381	331	0407087
200mm	406	356	0408087
250mm	457	407	0410087

The Firestop Spacer is not load bearing

Oil & Solid Fired Appliances With Flue Gas Temperatures Greater Than 250°C (>T250)

The following components **MUST** be used where iFlue is used on Solid Fuel or Oil fired appliances where the flue gas temperature exceeds 250°C and / or where the chimney system penetrates a combustible floor. Each ventilated component offers a 50mm clearance to combustible materials.

Ventilated Firestop Spacer

Used where the chimney passes through the upper combustible floors and where sections below the floor are enclosed within a fire protected shaft. This component is not load bearing.

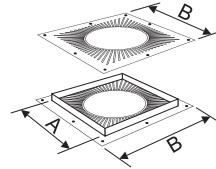

Flue Size	A (mm)	B (mm)	Code
100mm	251	349	0404082
130mm	281	379	0405082
150mm	301	399	0406082
180mm	331	429	0407082
200mm	351	453	0408082

Ventilated Ceiling Support

Used to both support and firestop the chimney system where it passes through the first combustible floor directly above the appliance. The support incorporates a patented intumescent matrix design which expands rapidly with temperature and seals the plate to prevent the potential spread of fire from the room below. The Ceiling Support can vertically support up to 6 Mtrs of product.

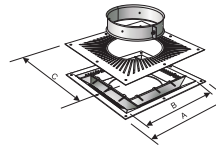

Flue Size	Dimensions (mm)			Code
	A	B	C	
100mm	331	251	349	0404107
130mm	361	281	379	0405107
150mm	381	301	399	0406107
180mm	411	331	429	0407107
200mm	431	351	453	0408107

For painted variations change the last figure of the part number from 7 to 6 for black and 5 for white, e.g. for 130mm white version 0405105.

Support Components

Wall Support Assembly

Used to take the vertical load of the chimney when supported from a wall. The Support is fully adjustable allowing varying clearances from the wall (50mm as standard). Requires M10 wall fixings. Refer to page 14 and 15 for load bearing information.

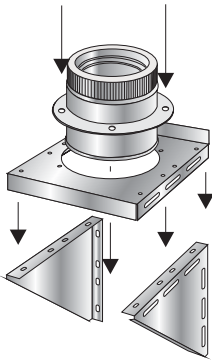

Flue Size	Dimensions (mm)		
	A	B	C
100mm	281	252	225
130mm	311	282	255
150mm	331	302	275
180mm	360	331	304
200mm	384	355	328
250mm	432	403	347

'C' - Wall Fixing Centres

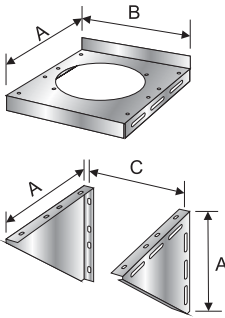

Flue Size	Stainless	Galvanised
	Code	Code
100mm	0404062	0404998
130mm	0405062	0405998
150mm	0406062	0406998
180mm	0407062	0407998
200mm	0408062	0408998
250mm	0410062	0410998

Anchor Plate

Designed to be used when connecting iFlue to a lintel or Pre-Cast Chamber. A short section of liner projects a nominal 32mm through the bottom of the plate. Installed length "H" is 51mm while "E" is 27mm and there are 8 x 11mm fixing holes at the centres shown in the table below. Manufactured in stainless steel. This component supports a maximum of 13 metres of product.

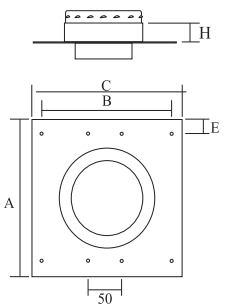
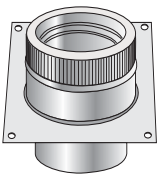

Flue Size	Dimensions (mm)			Code
	A	B	C	
100mm	281	196	252	0404089
130mm	311	226	282	0405089
150mm	332	246	302	0406089
180mm	360	275	331	0407089
200mm	384	299	355	0408089
250mm	432	345	403	0410089

Wall Bands

Wall Bands provide lateral support for the chimney and must be used at intervals not exceeding 3.0 metres above any load bearing support.

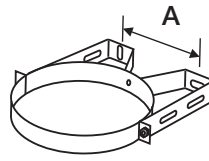

Flue Size	A (mm)	Code	
		Stainless	Galvanised
100mm	112	0404067	0404088
130mm	142	0405067	0405088
150mm	162	0406067	0406088
180mm	192	0407067	0407088
200mm	212	0408067	0408088
250mm	262	0410067	0410088

Wall Band (Extension Bracket)

Used with Wall Bands, these components allow the clearance between the wall and outer surface of the chimney to be increased by an additional 50mm.

Please note that the maximum distance between Wall Bands is reduced from 3.0 metres to 2.5 metres if using the Extension Brackets.

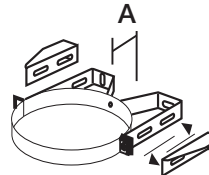

Flue Size	Dimensions (mm)		Code
	Min	Max	
100mm	50	100	0400067
130mm	50	100	0400067
150mm	50	100	0400067
180mm	50	100	0400067
200mm	50	100	0400067
250mm	50	100	0400088

Strut / Guy Wire Bracket

A 150mm installed length which incorporates a ring with three anchoring points to which guys, or preferably rigid stays, can be secured with M6 nuts and bolts. Manufactured from stainless steel.

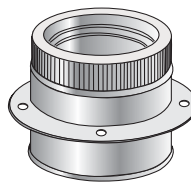

Flue Size	Code
100mm	0404092
130mm	0405092
150mm	0406092
180mm	0407092
200mm	0408092
250mm	0410092

System Components

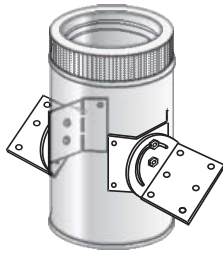

Roof Support

Provided with adjustable gimbal plates to permit a chimney to be supported on roof joists, trussed rafters etc. Maximum suspended chimney length supported is 6.0 metres and maximum total length supported is 9.0 metres.

Flue Size	Code
All Sizes	0105029

Angled Wall Cover Ring

The Wall Cover Ring is designed to offer an aesthetic trim around the chimney where it penetrates a wall. This component is available in two angle variations, 30° - 40° and 40° - 50°.

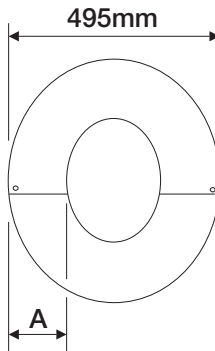

Flue Size	A mm	Code	
		30° - 40°	40° - 50°
130mm	156	0405140	0405150
150mm	146	0406140	0406150
180mm	131	0407140	0407150
200mm	121	0408140	0408150

Terminals

Storm Cowl

The Storm Cowl offers improved resistance to both rain and potential down draught conditions and is also available with an internal mesh for gas fired appliances. For use on oil and solid fuel appliances, it is not advisable to use the Storm Cowl with Mesh.

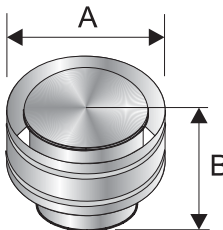

Flue Size	Code	
	With Mesh	No mesh
100mm	0404075	0404076
130mm	0405075	0405076
150mm	0406075	0406076
180mm	0407075	0407076
200mm	0408075	0408076
250mm	0410075	0410076

Flue Size	Dimensions (mm)	
	A	B
100mm	270	218
130mm	294	218
150mm	319	218
180mm	344	218
200mm	369	218
250mm	419	230

Rain Cap

The Rain Cap offers a degree of protection from rain and is suitable for oil and solid fuel fired appliances.

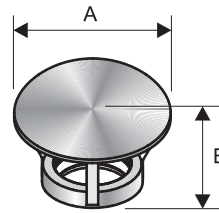

Flue Size	A (mm)	B (mm)	Code
100mm	255	221	0404074
130mm	255	226	0405074
150mm	300	245	0406074
180mm	358	273	0407074
200mm	402	316	0408074
250mm	500	328	0410074

Top Stub

The Top Stub offers the least resistance to flue gases and is ideal for use on solid fuel and oil fired appliances where there is drainage at the base of the chimney. The Top Stub is also available with mesh for use on Gas / Condensing Appliances.

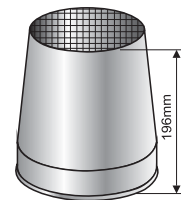
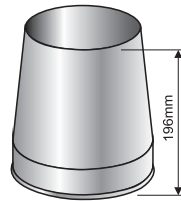

Flue Size	Code	
	With Mesh	No mesh
100mm	0404077	0404073
130mm	0405077	0405073
150mm	0406077	0406073
180mm	0407077	0407073
200mm	0408077	0408073
250mm	0410077	0410073

Weathering & Flashings

Malleable Aluminium Flashings

The Specflue Aluminium Flashing range offers a competitive alternative to lead flashing, while still maintaining a traditional design and malleable material. For use on flat tiles and slate roofs. All Aluminium Flashings require a Storm Collar.

Flat Flashing

For flat or nearly flat roofs.

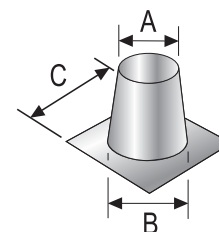

Flue Size	Dimensions (mm)			Code
	A	B	C	
100mm	160	250	455	0104038
130mm	190	280	495	0105038
150mm	210	300	495	0106038
180mm	240	330	610	0107038
200mm	260	350	610	0108038
250mm	310	400	610	0110038

Weathering & Flashings Con't

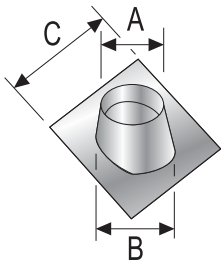

5° - 30° Flashing
For low pitched roofs

Flue Size	Dimensions (mm)			Code
	A	B	C	
100mm	160	247	455	0104035
130mm	190	281	495	0105035
150mm	210	304	495	0106035
180mm	240	335	610	0107035
200mm	260	361	610	0108035
250mm	310	419	610	0110035

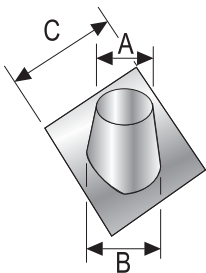

32° - 45° Flashing
For high pitched roofs

Flue Size	Dimensions (mm)			Code
	A	B	C	
100mm	160	332	559	0104036
130mm	190	375	578	0105036
150mm	210	403	610	0106036
180mm	240	428	650	0107036
200mm	260	475	678	0108036
250mm	310	546	737	0110036

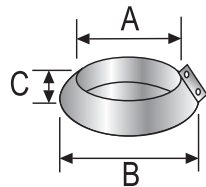

Storm Collar
Used to weather the top of the Flashing.
Supplied with a tube of silicon sealant.

Flue Size	Dimensions (mm)			Code
	A	B	C	
100mm	152	255	70	0104041
130mm	177	280	70	0105041
150mm	202	301	70	0106041
180mm	227	330	70	0107041
200mm	252	351	70	0108041
250mm	302	401	70	0110041

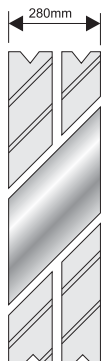

Wall Sleeve
Must be used where a 135° Tee is used to pass the chimney through an external wall. The sleeve component provides, in effect, an uninterrupted run through the wall.

Flue Size	Code
100mm	0404050
130mm	0405050
150mm	0406050
180mm	0407050
200mm	0408050
250mm	0410050

EPDM Synthetic Rubber Flashings

These flashings offer an installation friendly alternative to the traditional type of roof flashing. The EPDM Flashings are available in three sizes which cover an external diameter range between 100mm and 250mm internal diameter.

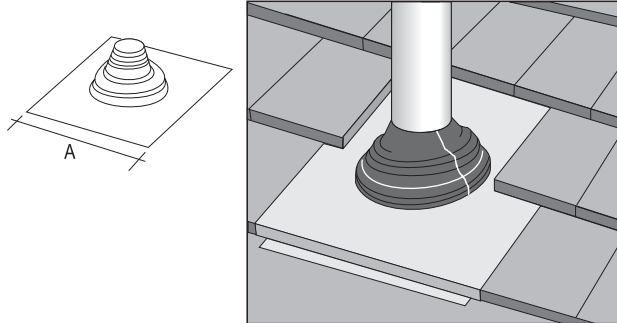

The selection of the correct Flashing depends on the outside chimney diameter and intended roof pitch. The table identifies which of the three different sized flashings should be used. Each consists of a malleable aluminium base to which an EPDM rubber cone is sealed. The cone is easily trimmed on site to suit the external diameter of the chimney. Separate Installation Instructions are provided with every flashing.

The EPDM Flashing system will effectively seal and remain pliant over a wide range of external chimney surface temperature extremes from -30° to 115°C. The EPDM cones have also been proven to withstand intermittent surface temperatures of up to 150°C. EPDM Flashings should not be used on single wall chimney systems serving solid fuel appliances or any application where the potential surface temperature of the chimney will exceed the maximum design temperatures detailed above. Please consult Specflue Technical Dept. for further information.

Flue Size	Ext. Dia (mm)	Roof Pitch	Flashing No	Cone Index
				Cut line
100mm	150	0-45°	2	C
130mm	180	0-40°	2	E
150mm	200	0-30°	2	F
150mm	200	0-45°	3	C
180mm	230	0-40°	3	D
200mm	250	0-35°	3	F
250mm	300	0-30°	3	I
250mm	300	0-45°	4	A

Flashing Size	Code	Base Size (A)
Flashing No. 2	0502035	600mm x 600mm
Flashing No. 3	0503035	764mm x 764mm
Flashing No. 4	0504035	956mm x 956mm

General.

1 The system is designed to be used both internal and external to a building. The range of components will permit deliberate drainage of condensate, either back to the condensate removal components within the iFlue System range, or through the heating appliance. No part of the flue system should be constructed to form an angle greater than 45° from the vertical. Although components are included that will permit horizontal applications, they should only be used for connection to the appliance. Where the system is being used for a condensing application, sections must run at an angle of no less than 5° from the horizontal, using the Tees, Elbows and fittings designed for that purpose. Failure to provide adequate drainage may cause premature failure of the seals.

Regulations

2 Where the flue passes through combustible floors it is important that the correct firestop components are used and the correct distance to combustible material is observed. All Firestop and Support components within the iFlue range are designed to offer a minimum clearance to combustible material of 50mm. In all instances the requirements of the Building Regulations must be complied with and the appropriate references are: Document J of the DOE Building Regulations, Section F of the Building Standards (Scotland), Section L of the Building Regulations (Northern Ireland). Reference should also be made to the relevant British and European Standards governing the installation of flue and chimney products for the associated fuel and appliance types as detailed:

Solid Fuel and Oil Fired Applications: BS EN15287-1 Domestic Gas Installations: BS5440: Part 1: 2008

Note: In the UK, connection to an appliance which is not connected to the fuel supply, may be carried out by a competent person. However connection to an appliance that is connected to the fuel supply must be carried out by an approved and registered Heating Engineer, e.g. The Gas Register, HETAS (Solid Fuel) or OFTEC (Oil).

For other European countries, reference should be made to EN 15287-1 and their associated National Annex NA.

Jointing

3 The iFlue system is built from the bottom upwards. The joints are made by fitting a female end over the preceding crimped male end, and then applying a Locking Band. Depending on application, the joint can be made pressure and moisture resistant using the separately ordered Joint Seal. This must be located and secured by the user in the appropriate groove as shown in Figs. 1 & 2. Prior to making the joint, the surface of the seal should be lubricated with a silicon-based lubricant. Note that the lips of the seal must only point down towards the appliance as shown.

Adjustable Length

4 The Adjustable Length consists of two sections which slide together. Both sections are insulated, and the component is supplied with additional insulation, which will need to be added to the annulus on site depending on the desired finished length. The overlapping section should be secured with the 6 self tapping screws provided. Each end of the assembly is secured with Locking Bands in the normal manner. The Adjustable Length does NOT load bear. Always use a Wall Support or a Support Plate immediately above this component when vertically applied. Where pressure and moisture resistance are required an additional seal is required within the slip section, see Fig 2.

Fig. 1 Jointing & Seal Location

If using a seal, ensure that the surface has been lubricated with a suitable silicon lubricant and that the mating male end is clean and free of dirt / grit.

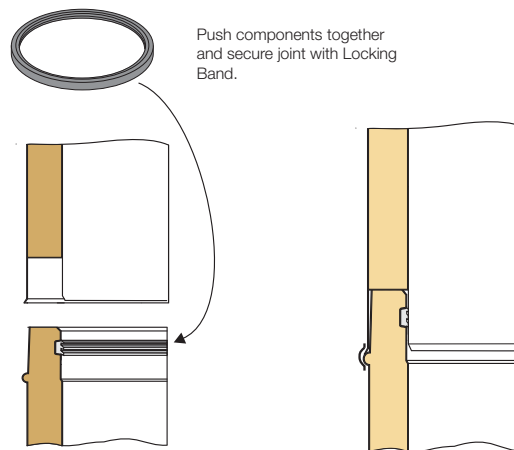

Appliance connection and condensate removal.

5 The Appliance Connector or associated Adaptor should be used to facilitate connection from the appliance to the chimney. It is recommended that the joint between the adaptor and the appliance / flue pipe is securely caulked and sealed with fibre rope and fire cement. Any flue pipe connection to the chimney MUST be made in the same room. Condensation removal should be determined by each individual application. All drain components feature a short length of 1" BSP threaded stainless steel tube to which an appropriate drain connection can be made. Where used on appliances that produce high levels of condensation such as condensing boilers, the chimney system should be designed so that there is a minimum 5° incline from the horizontal, ensuring the flow of condensation back to a drainage point. Components such as the 85° and 40° Elbows, 95° Tee, Duct Drain and Condensate Collector are all available to ensure the correct removal of condensation from the system.

General Design Considerations

6 The internal diameter of the chimney must conform to the requirements of the heating appliance manufacturer's instructions, and should not, under any circumstance, be less than the appliance outlet. The height of the chimney will depend on the building structure, however it is recommended that not less than 4.5 metres should be considered the minimum chimney height from the appliance to termination for solid fuel applications.

7 No part of the system should be constructed at an angle of greater than 45° from the vertical. The only permitted exception is where the appliance is flued from the rear, in which case it is recommended that a 45° elbow is used with a 135° Tee to take the chimney vertical. Alternatively a swept 90° Elbow could be used directly off the rear of the appliance, however in all cases, the maximum horizontal length between the appliance outlet and the chimney must not be greater than 150mm. Where a change of direction or offset is required, 15°, 30° and 45° Elbows should be used, however under Building Regulations, only one offset should be used in any chimney run. This however excludes any elbows used to make the connection to the appliance.

Fig. 2: Adjustable Length

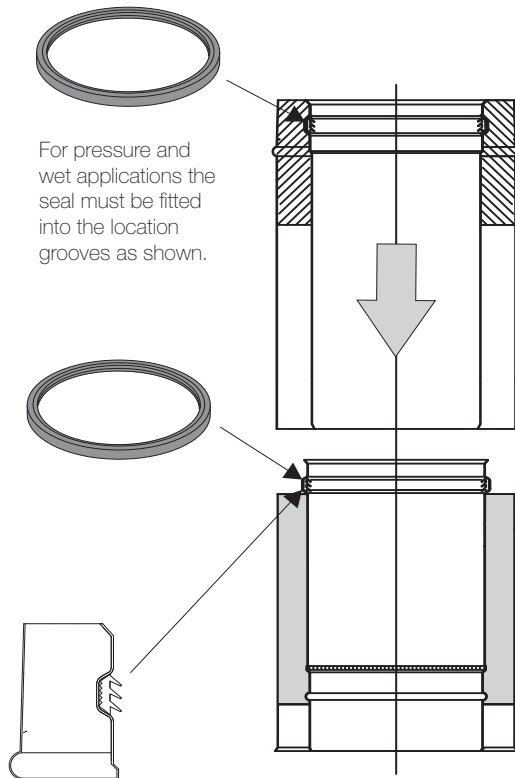

For pressure and wet applications the seal must be fitted into the location grooves as shown.

Ensure seal vanes only face downwards

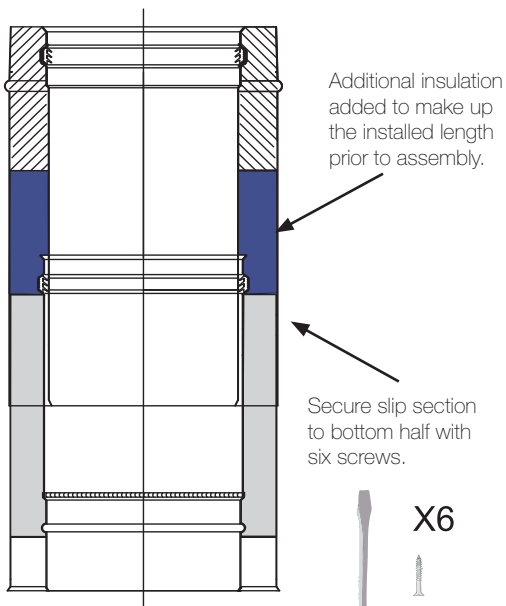

Additional insulation added to make up the installed length prior to assembly.

Secure slip section to bottom half with six screws.

X6

Where an offset is used, the length of the chimney between two elbows MUST NOT exceed 20% of the total height of the chimney. Offsets must always be supported both above and below both ends using a Wall Band and at an angle no greater than 45°.

8 The chimney must be adequately supported throughout its length and the iFlue product offers a range of lateral and vertical support components to undertake the safe installation of the chimney system. Wall Bands are available for both internal and external applications and should be installed every 3.0 metres. Where used externally, the stainless steel version should be used. For detailed loading information, please refer to Pages 14, 15 and 18.

Floor Penetration Components

9 Where the iFlue product is used on SOLID FUEL or OIL appliances and where the flue gas temperature exceeds 250°C, the clearance at floor / ceiling joists must be established using the Ventilated Ceiling Support and Ventilated Firestop, ensuring that no joints are made within the floor / ceiling void. When connected to a single wall flue pipe, iFlue must project below the appliance room ceiling by a minimum of 3 X OD of the single wall flue pipe before a connection is made. All support components offer a 50mm clearance to combustible material that must be maintained at all times. See Fig. 3, 4 & 5.

Fig. 3 Ventilated Ceiling Support

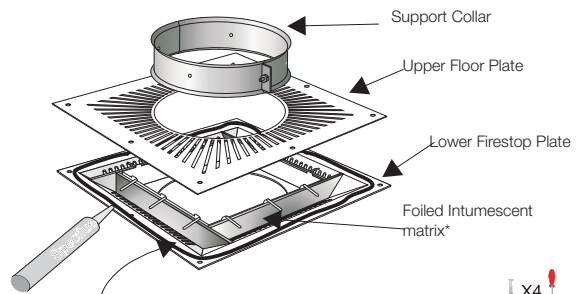

Apply a substantial bead of intumescent sealant to the upper surface of the Lower Firestop Plate.

This component MUST be used within a four sided fire resistant board lined timber frame within the thickness of the floor.

*Intumescent materials swell and seal gaps very rapidly when subjected to fire.

Fig. 4 Ventilated Firestop

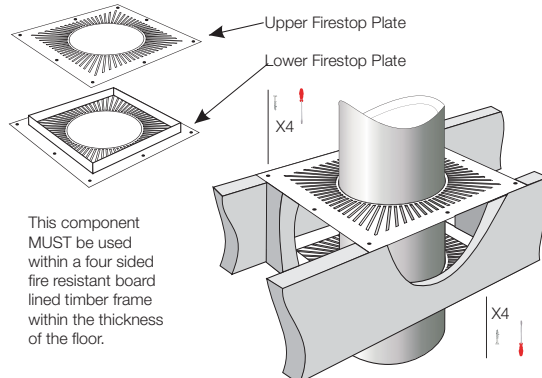

This component MUST be used within a four sided fire resistant board lined timber frame within the thickness of the floor.

Fig. 5 Typical Configuration

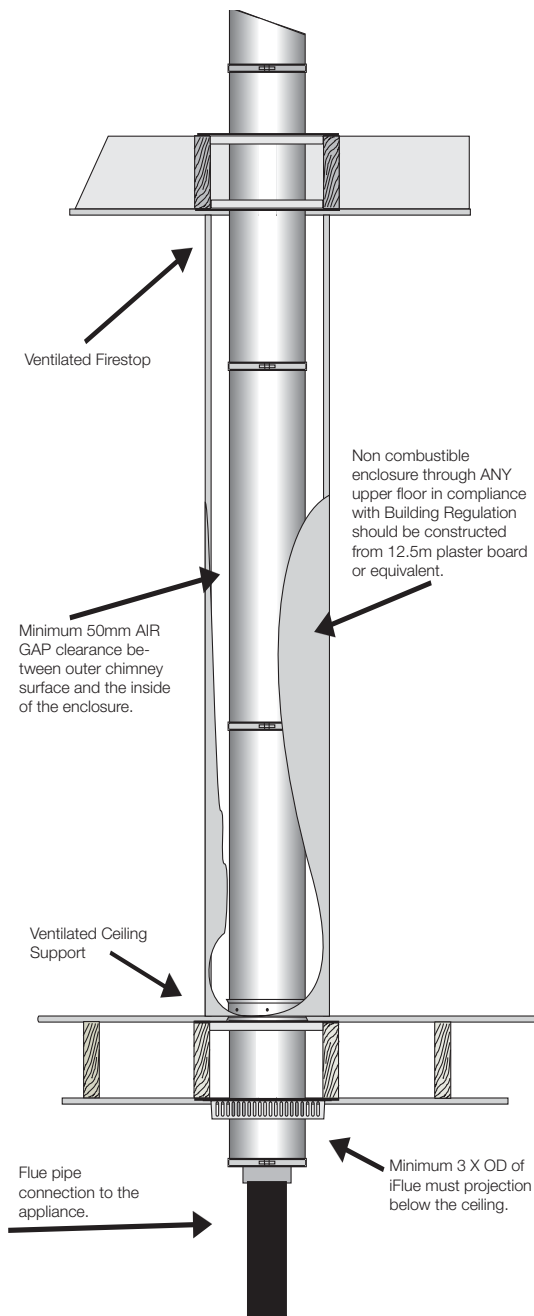

Note: All Ventilated Support Components are supplied with their own detailed installation instructions which must be followed.

10 Where iFlue is applied internally and serves a gas fired appliance where the flue gas temperature will not exceed 250°C, and / or passing through a non-combustible floor or ceiling, the following solid Ceiling Support and Firestop plates are used. These components offer support and fire stopping of the chimney at ceiling level directly above the appliance. See Fig. 7.

Fig. 6 Framing Data For Ventilated Components

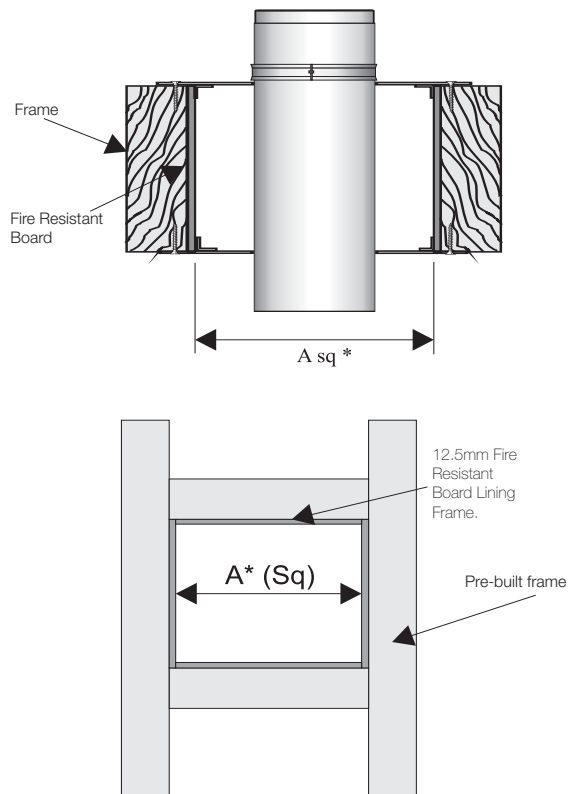

* Inside fire resistant enclosure.

Framing Data		
Product		'A' Sq (mm)
iFlue	100mm	251
	130mm	281
	150mm	301
	180mm	331
	200mm	351

Fig. 7 Ceiling Support

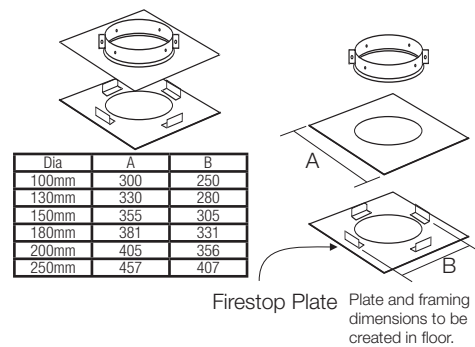

Framing Data - Ceiling Support & Firestop						
Flue Size (mm)	100	130	150	180	200	250
'B' Square	250	280	305	331	356	407

Fig. 8 Roof Support

- A Gimbal Plate
- B Quadrant Plate
- C Coach Bolts

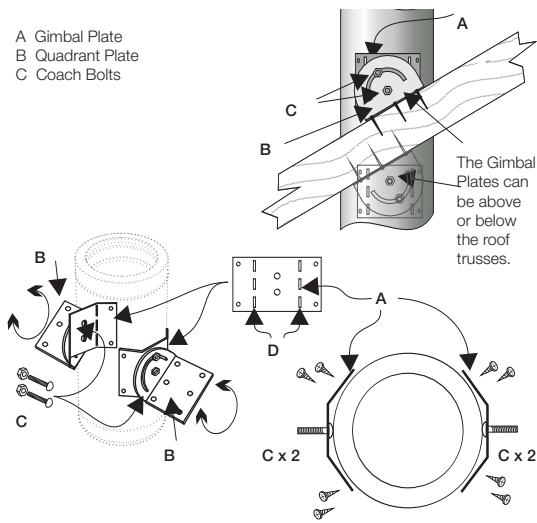

- 1 Bend the Gimbal Plates down the slotted fold lines D, so that when the coach bolts are in position. The component fits the curvature of the surface of the chimney.
- 2 Loosely assemble the Gimbal and Quadrant Plates using the coach bolts provided. Position the lower edge of the Gimbal plate, angled and supported on the roof structure.
- 3 Secure the Gimbal Plate to the outside of the chimney with the self-tapping screws provided, and the Quadrant Plate to the roof structure with substantial wood screws. This sequence will vary as the required positioning is determined, and to enable the vertical alignment of the chimney.
- 4 Fully tighten the nuts on the coach bolts.

Wall Supports

11 The kit consists of a Support Plate, two Wall Support Side Brackets and a Support Length. As the Plate can be moved on the Side Brackets to adjust the wall clearance, the actual loading capability will vary depending on the chimney diameter used and the Side Bracket orientation. The Support Plate may also be used on its own or with other suitable support arrangements. In either case it is always used with a Support Length, bolted to the top surface of the Support Plate with fittings supplied, see Fig. 9 and Fig. 10.

Wall Supports must be secured to the structure with fixings adequate for the purpose.

Maximum compressive Load of straight lengths between Wall Support Assembly (Closed) - See Fig. 10 Dim. A

Flue Size	Maximum Load A (Closed)	Maximum Load A (Open)
100mm	30m	25m
130mm	30m	25m
150mm	30m	25m
180mm	20m	15m
200mm	20m	15m
250mm	20m	15m

Fig. 9 Wall Support Assembly

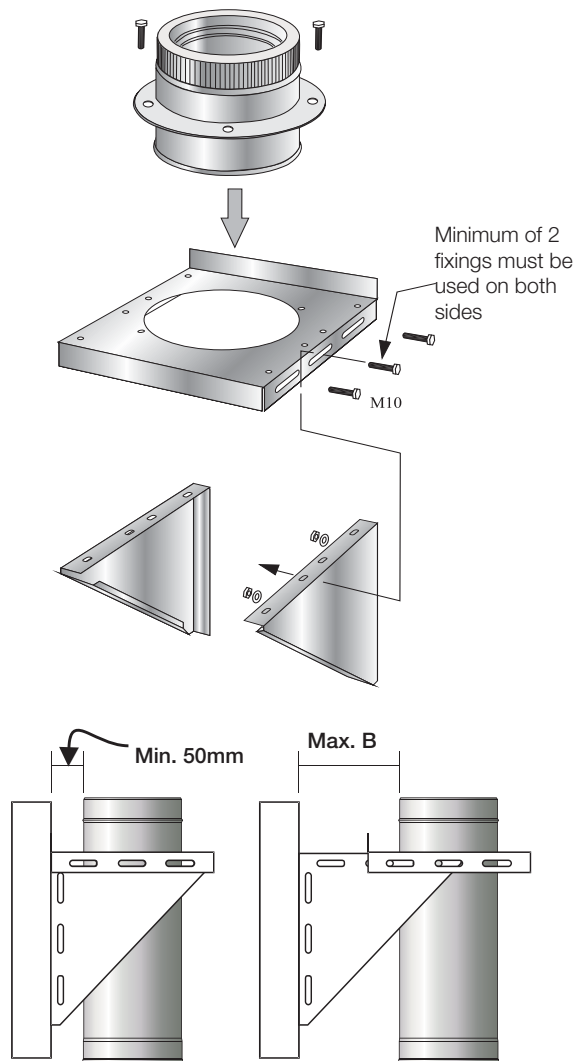

Dia (mm)	Max. Wall Clearance B	Dia (mm)	Max. Wall Clearance B
100mm	150mm	180mm	200mm
130mm	150mm	200mm	200mm
150mm	150mm	250mm	200mm

Maximum height above chimney inlet using Wall Support Assembly (Closed) and lateral bracing requirements. See Fig. 10 Dim. B & C.

Flue Size	Max. Distance Between Support Components	
	B	C
100mm	3.0m	16m
130mm	3.0m	15m
150mm	3.0m	15m
180mm	3.0m	15m
200mm	3.0m	14m
250mm	3.0m	10m

Fig 10 Support Components

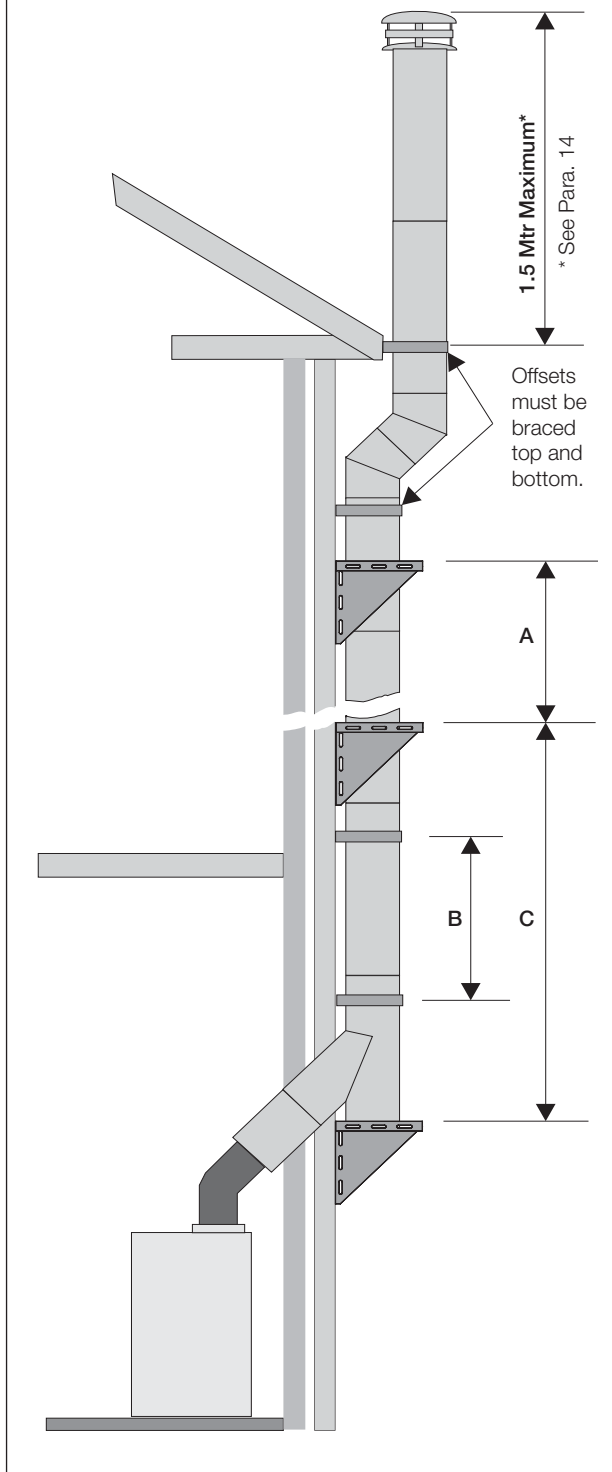

12 The Wall Band consists of two components, the Back Fixing Bracket complete with Back Ring and the Front Securing Ring. For installation, unscrew the fixing bolts and remove the Front Securing Ring. The Back Ring can be rotated 90° to facilitate access to the fixing slots in the Rear Fixing Bracket. Ensuring the Rear Fixing Plate is level, mark the hole positions and drill fixing holes. The fixings should be of adequate size to securely attach the Wall Band to the wall. Position Rear Fixing Bracket against wall and secure to wall with suitable fixings. Rotate the Back Ring back to its original position so that the fixing holes of the Back Ring align with the Nut Inserts on the Rear Fixing Bracket. Position the chimney against the Back Ring and secure the Front Ring with the M8 Bolts provided. See Fig. 11.

Fig. 11 Wall Band Assembly

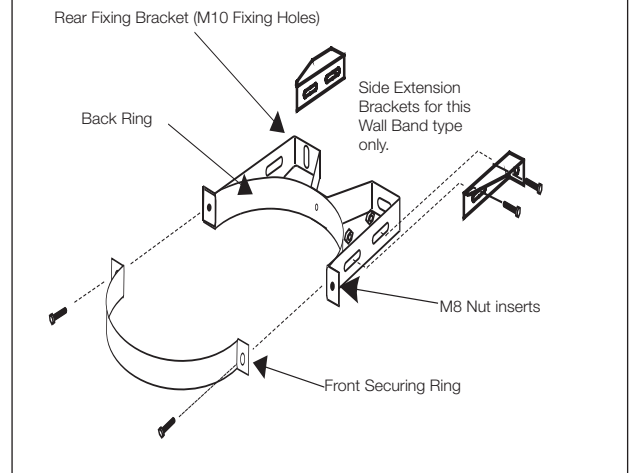
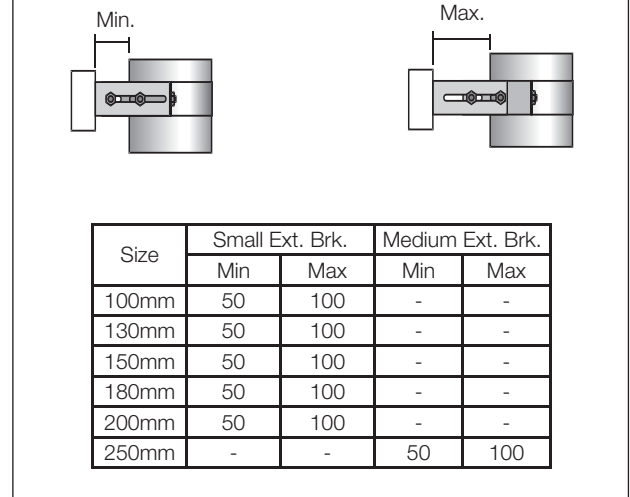

Fig. 12 Wall Band Extension Brackets



Wall band Extension Brackets can be used to extend the clearance from the wall from 50mm to approx. 100mm as detailed in Fig. 12. Where applied externally the maximum distance between lateral supports (Wall Bands) as detailed in Fig. 10 must be reduced from 3.0 metres to 2.5 metres.

Structural Locking Band

13 Although the maximum free standing height above the last support is 1.5 metres, this can be increased to a maximum of 3.0 metres by the use of Structural Locking Bands. Where a free standing height of 3.0 metres is required, the installation must comply with the requirements detailed in Fig. 13. Structural Locking Bands must be installed on the first joint directly above the last support and at every other joint throughout the 3.0 metres free standing height.



The Structural Locking Band must be applied over the upper most length and positioned around the preceding joint. The band is then secured and tightened around the joint with the two M8 bolts. Once the Structural Locking Band is in position, carefully using a 3.5mm drill bit, drill through the circumferential holes in the Structural Locking Band, penetrating the outer case of the chimney, taking care not to drill through the actual chimney liner. Using a suitable rivet gun, fix the band to the outer case of the chimney using the supplied 3.3mm pop rivets.

Fig. 13 Structural Locking Band positions

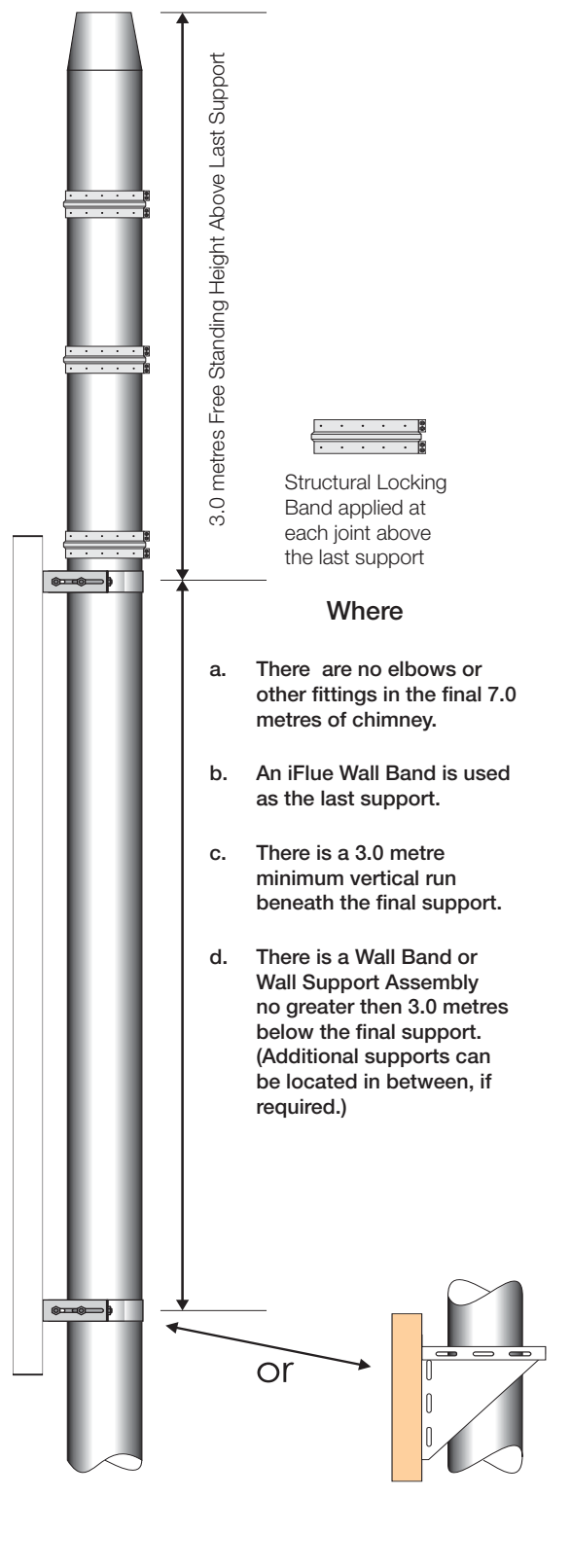

Chimney Termination Heights

14 Chimney termination heights and positions are subject to current Building Regulations and National Standards. The chimney height requirements for domestic solid fuel and oil applications are detailed within BS EN 15287-1: 2007. Domestic natural gas fired appliances are governed by BS5440-1: 2008.

All other European countries are governed by their own Regulations, however reference can be made to the countries National Annex for individual member state requirements.

Should it be necessary to construct the chimney so that it extends beyond 1.5 metres above the roof or last support, such extension MUST be provided with additional support. A Guy Wire Bracket should be used for this purpose, to which rigid stays, preferably angle iron, should be connected. Where the installation meets the requirements of Fig. 13, Structural Locking Bands can be used to extend the free standing height to a maximum of 3.0 metres above the last support.

If the chimney serves an oil fired appliance with a pressure jet burner, the chimney must discharge a minimum 600mm above the roof penetration point, or any adjacent structure, if it is within 750mm. It must also be at least 600mm from any opening into the building and 300mm from any combustible material.

Where used with an oil fired appliance with a vaporising burner, termination must comply with the details in figure 14. Where terminating above a solid fuel appliance, termination heights must comply with Fig. 14. Where the chimney service a gas fired appliance, termination heights should comply with the information detailed in Fig. 15, 16, 17 and 18.

Fig. 14 Terminal over solid fuel, wood and vaporising oil fired appliances.

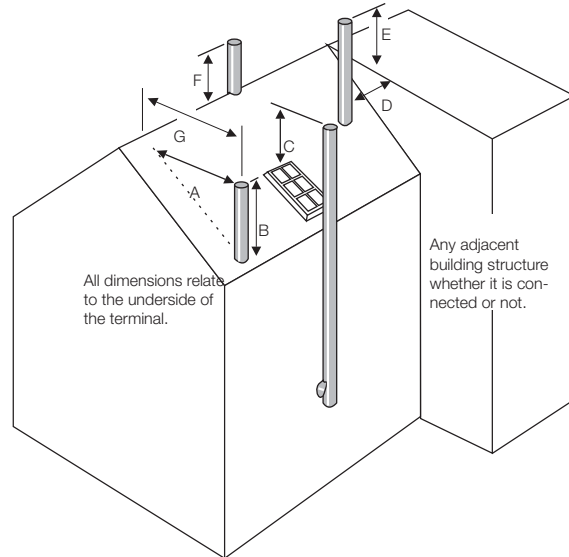

A	2.3 metres horizontally clear of the roof surface, e.g. if the roof pitch is 45°, then the chimney should project 2.3 metres above the roof penetration.
B	1.0 metre, providing 'A' is satisfied, or 600mm above the ridge if 'G' is less than 600mm.
C	1.0 metre above the top of any flat roof, and the top of any openable roof light, dormer window or ventilator, etc., if it is located within 2.3 metres.
D/E	If 'D' is less than 2.3 metres, 'E' shall not be less than 600mm above the structure.
F	600mm above the ridge.
G	Edge of chimney to roof.

Fig. 15 Termination over gas appliance

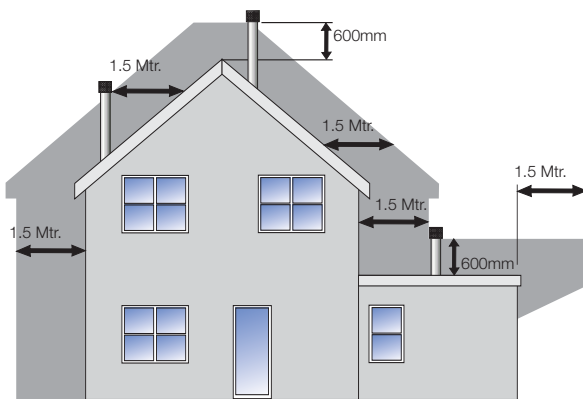

No part of the flue outlet shall be less than 1.5 Mtr. measured horizontally to the roof surface, or any wall. Where the flue terminates above the ridge, it shall do so by not less than 600mm, other than where the flue terminates with a purpose designed ridge terminal.

Fig. 16 Terminal on flues serving gas fired appliances adjacent to windows or openings on pitched and flat roofs.

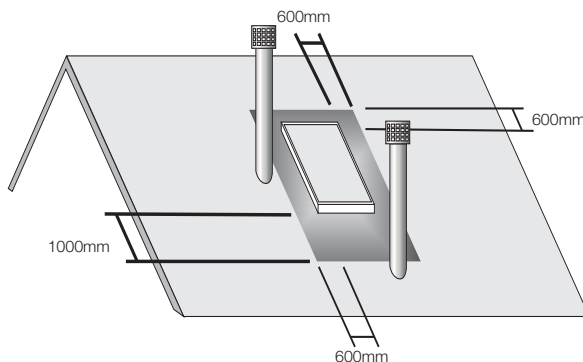

The flue shall terminate outside of the shaded zone.

Fig. 17 Termination through an extension roof adjacent to a taller flat roof building (Gas Appliances).

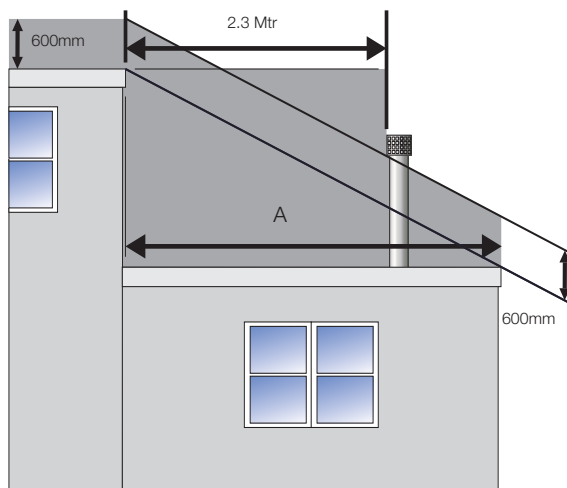
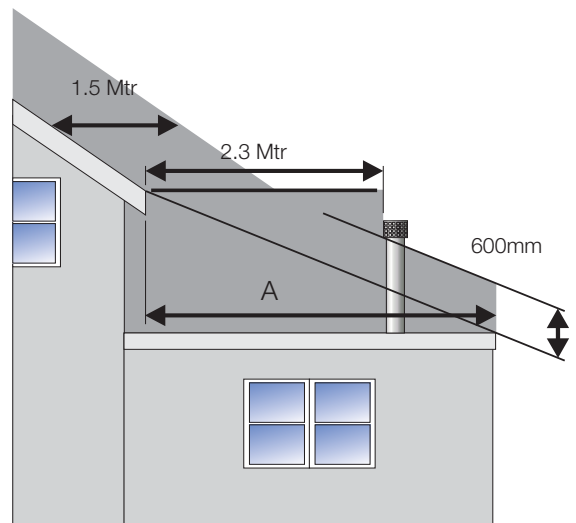

Fig. 18 Termination through an extension roof adjacent to a taller sloped roof building (Gas Appliances).



The flue shall terminate outside of the shaded zone.

Where passing through a roof of an extension or lower part of a building, the terminal must be located not less than 2.3 metres from the structure.

It must also terminate not less than 600mm above an imaginary line drawn between the outer edge of the extension, or 10 metres, (A), whichever the longer, and the edge of the higher roof, including any roof of an adjacent but separate building. See Fig. 17 & 18.

15 Components within the range that are manufactured from only single skin, can be vulnerable when exposed to the products of combustion from solid fuel appliances. This is especially true for terminals, however in the majority of cases, an open-ended terminal better suits appliance performance, but it is acknowledged that on occasions, other types of terminals from the range have to be used to reduce rain entry. The condensate Collector and Locking Plug when used on solid fuel are also vulnerable to flue gas by-products, particularly if the chimney is not regularly maintained and cleaned.

Such components are considered sacrificial and their life expectancy will vary depending on application, location, maintenance and fuel usage. For this reason, these items are only covered by a twelve month manufacturing defects warrantee.

16 It should also be noted that chemically contaminated combustion air will also affect the durability of the product as will the use of chemical chimney cleaners. Typical examples of contaminated combustion air has been seen in de-greasing plants and dry-cleaning companies

17 Where used on solid fuel, care should be taken to ensure that only high quality fuel is used. Specflue do not recommend fuels such as petroleum coke or other fuels containing a blend of petroleum coke. Also some smokeless fuels contain halogens that are released when burned, forming Hydrochloric and Hydrofluoric Acids. These fuels can lead to premature failure of the chimney system through corrosion. Before burning any fuel, Specflue would suggest that written confirmation is obtained to ensure that the fuel is halogen free.

18 Some Bio Fuels when burnt give off aggressive and corrosive acids which attack and cause premature failure of stainless steel components. Written confirmation should be obtained to confirm that the proposed Bio Fuel does not have an accelerated detrimental effect on the iFlue.

Installation Instructions

19 External protection should also be applied where the product is installed externally in coastal locations. This could be achieved using a specialist protective coating or by painting the outer case. Only stainless steel components should be used for external applications.

Handling

20 The product is relatively easy to handle, but care should be taken when holding, fitting or assembling any part of the system. Users are advised to take suitable precautions, gloves etc, to avoid injury on any sharp exposed edges.

Data Plate

21 It is a regulatory requirement that a data plate is to be completed, positioned and secured by the installer where a hearth, fireplace, flue or chimney is provided or extended. The data plate provides essential information regarding the performance, specification, designation and installation for the chimney system. The data plate is to be completed by the installer using an indelible ink and securely fixed in an unobtrusive but obvious position. Acceptable fixing positions would be next to the electricity consumer unit, water supply stop cock or gas meter within the building or by the chimney / hearth.

Some data plates contain more or less information than detailed below, it is a requirement that all data plates have to provide the essential information deemed necessary under the regulatory requirement, as follows:-

Property address.

Where the chimney / hearth is installed.

What fuels the chimney is suitable for (firing capacity).

Is the chimney suitable for condensing appliances / applications.

Chimney internal diameter.

Installers name and address.

Date of installation.

Distance to combustible material.

Product designation of the chimney to EN 1443, if relevant (See front page).

Provision for sweeping and cleaning

22 Adequate provision should be made for inspecting and cleaning the chimney system. This is particularly important for solid fuel applications.

Specfue would recommend that chimneys serving solid fuel appliances are swept as frequently as necessary but at least twice a year and possibly three times a year if the appliance is subject to long periods of slumbering.

Access components are made available within the range and should be installed to suit the installation, unless sweeping can be undertaken through the appliance.

It is important that a visual inspection of the chimney is undertaken at the same time to ensure all joints are sound and there is no evidence of a chimney fire having occurred.

Testing

23 This is achieved by means of a flue flow test as detailed in BS5440: Part 1: 2008. This can be summarised as follows: After completing a visual and physical check of the system and joints, and ensuring adequate air supply for combustion has been provided in accordance with the appliance requirements, close all doors and windows in the room in which the appliance is installed. Carry out a flow visualization check using a smoke pellet that generates at least 5m³ of smoke in 30s by placing the smoke pellet in the intended location of the appliance. Ensure that there is discharge of smoke from the correct terminal only and no leakage into the room.

When the chimney is tested, there should be:

- No significant escape of smoke from the appliance position.
- No seepage of smoke over the length of the chimney.
- A discharge of smoke from only the correct terminal.



If these conditions are not met, then the test has failed and all faults must be rectified and the system re-tested and passed before connection of the appliance to the fuel supply is undertaken. For further information please refer to the relevant standards and publications.

Note: A smoke test is subjective and by the nature of the product standards a chimney is allowed a degree of leakage as defined in BS EN 1856-1. For this reasons some wisps of smoke may be seen over the length of the chimney and this should not necessarily constitute a failure. It is therefore a matter of expert judgement as to whether significant leakage constitutes a failure. A product with a performance designation under EN 1856-1 with a leakage classification of N1 is allowed a maximum leakage rate of up to 2.01l/m² at a positive pressure of 40Pa.

For further information and guidance please refer to Appendix E of the Building Regulations Part J, BS EN 15287-1: 2007 and BS 5440: Part 1: 2008.

Maximum Loading Conditions In Metres.

Components	Diameter (mm)					
	100	130	150	180	200	250
Inspection Length	16	15	15	15	15	12
Ceiling Support	6	6	6	6	6	6
Ventilated Ceiling Support	6	6	6	6	6	6
Anchor Plate	13	13	13	13	13	13
95° & 90° Tee	16	15	15	15	15	12
135° Tee	16	15	15	15	14	10

IMPORTANT SAFETY INFORMATION 	
Property Address: The House, High Street, Bristol, Avon	
The chimney installed in the <input type="checkbox"/> Ground Floor <input type="checkbox"/> Lounge <input checked="" type="checkbox"/> Kitchen <input type="checkbox"/> First Floor <input type="checkbox"/> Dining Room <input type="checkbox"/> Boiler Room	Are suitable for (Fuel Type) <input checked="" type="checkbox"/> Gas <input type="checkbox"/> Oil (.....Sec) <input type="checkbox"/> Solid Fuel <input type="checkbox"/> All Suitable for condensing appliances <input checked="" type="checkbox"/> Yes <input type="checkbox"/> No
Chimney Designation to BS EN 1443 Temperature Pressure Capability Condense Resistance Corrosion Resistance Sootfire Resistance <input type="checkbox"/> T200 <input checked="" type="checkbox"/> N1 (40Pa @ 2.0 l.s ⁻¹ .m ²) <input type="checkbox"/> W (WET) <input checked="" type="checkbox"/> V1 <input checked="" type="checkbox"/> G (Yes) <input checked="" type="checkbox"/> T450 <input type="checkbox"/> P1 (200Pa @ 0.006 l.s ⁻¹ .m ²) <input checked="" type="checkbox"/> D (DRY) <input type="checkbox"/> V2 <input type="checkbox"/> O (No) <input type="checkbox"/> T600 <input type="checkbox"/> H1 (5000Pa @ 0.006 l.s ⁻¹ .m ²) <input type="checkbox"/> V3 <input type="checkbox"/> Vm	
Internal diameter of chimney: 150 mm Distance to combustible material (XX): 50 mm  Chimney Product Brand: iFlue	
Installation Details Company Name: Wonder Plumb Services Installed by: A Plumber Address: Address 1 City County Post Code Date of Installation: 3rd September 2006 Phone Number:	
Important Information This chimney system must be cleaned and inspected on a regular basis. In any event, this should not be less than once per year and should be undertaken by an authorised sweep. Under no condition should black steel sweeping brushes or chemical chimney cleaners be used with this product. It is a requirement both under Building Regulations and CE that this plate is completed and installed within the guidelines contained therein.	

Elbow and Offset Dimensions

Offset Data and Dimensions For Standard Elbow Configurations (See Fig. 19)

Flue Size	Dimensions in mm															
	15° Elbow				30° Elbow				40° Elbow				45° Elbow			
	A	B	C	D	A	B	C	D	A	B	C	D	A	B	C	D
100mm	86	370	49	97	86	351	94	97	86	332	121	97	86	321	133	97
130mm	93	397	52	104	93	377	101	104	93	357	130	104	93	345	143	104
150mm	97	413	54	108	97	392	105	108	97	371	135	108	97	358	148	108
180mm	103	436	57	112	103	414	111	112	103	392	143	112	103	379	157	112
200mm	107	452	60	118	107	429	115	118	107	406	148	118	107	393	163	118
250mm	118	491	65	129	118	467	125	129	118	442	161	129	118	427	177	129

Elbow Offset Chart Incorporating Standard Lengths (See Fig. 20)

Flue Size	Offset With 117mm Length							
	15° Offset		30° Offset		40° Offset		45° Offset	
	B	C	B	C	B	C	B	C
100mm	482	79	452	153	422	196	404	216
130mm	510	83	478	159	446	205	428	226
150mm	526	85	493	163	460	210	441	231
180mm	549	88	516	169	482	218	462	240
200mm	565	90	531	173	496	223	475	245
250mm	604	95	568	183	531	236	510	260

Flue Size	Offset With 241mm Length							
	15° Offset		30° Offset		40° Offset		45° Offset	
	B	C	B	C	B	C	B	C
100mm	602	111	560	214	517	276	491	303
130mm	630	115	586	221	541	285	515	313
150mm	646	117	601	225	555	290	529	319
180mm	669	120	623	231	577	298	549	327
200mm	685	122	638	235	591	303	563	333
250mm	724	127	675	245	626	316	597	347

Flue Size	Offset With 493mm Length							
	15° Offset		30° Offset		40° Offset		45° Offset	
	B	C	B	C	B	C	B	C
100mm	846	176	778	340	710	438	670	482
130mm	873	180	804	347	734	447	693	491
150mm	889	182	819	351	749	452	707	497
180mm	913	185	841	357	770	460	728	506
200mm	928	187	856	361	784	465	741	511
250mm	968	192	893	371	819	478	775	525

Flue Size	Offset With 993mm Length							
	15° Offset		30° Offset		40° Offset		45° Offset	
	B	C	B	C	B	C	B	C
100mm	1329	306	1211	590	1093	759	1023	835
130mm	1356	309	1237	597	1117	768	1047	845
150mm	1372	311	1252	601	1131	773	1061	851
180mm	1396	314	1274	607	1153	781	1081	859
200mm	1411	317	1289	611	1167	786	1095	865
250mm	1451	322	1326	621	1202	799	1129	879

Fig. 19

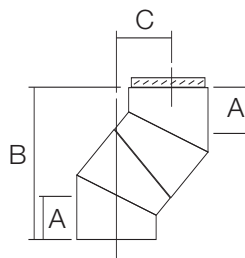
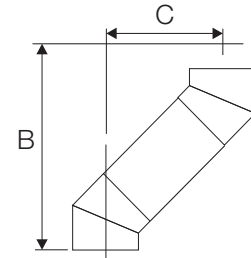
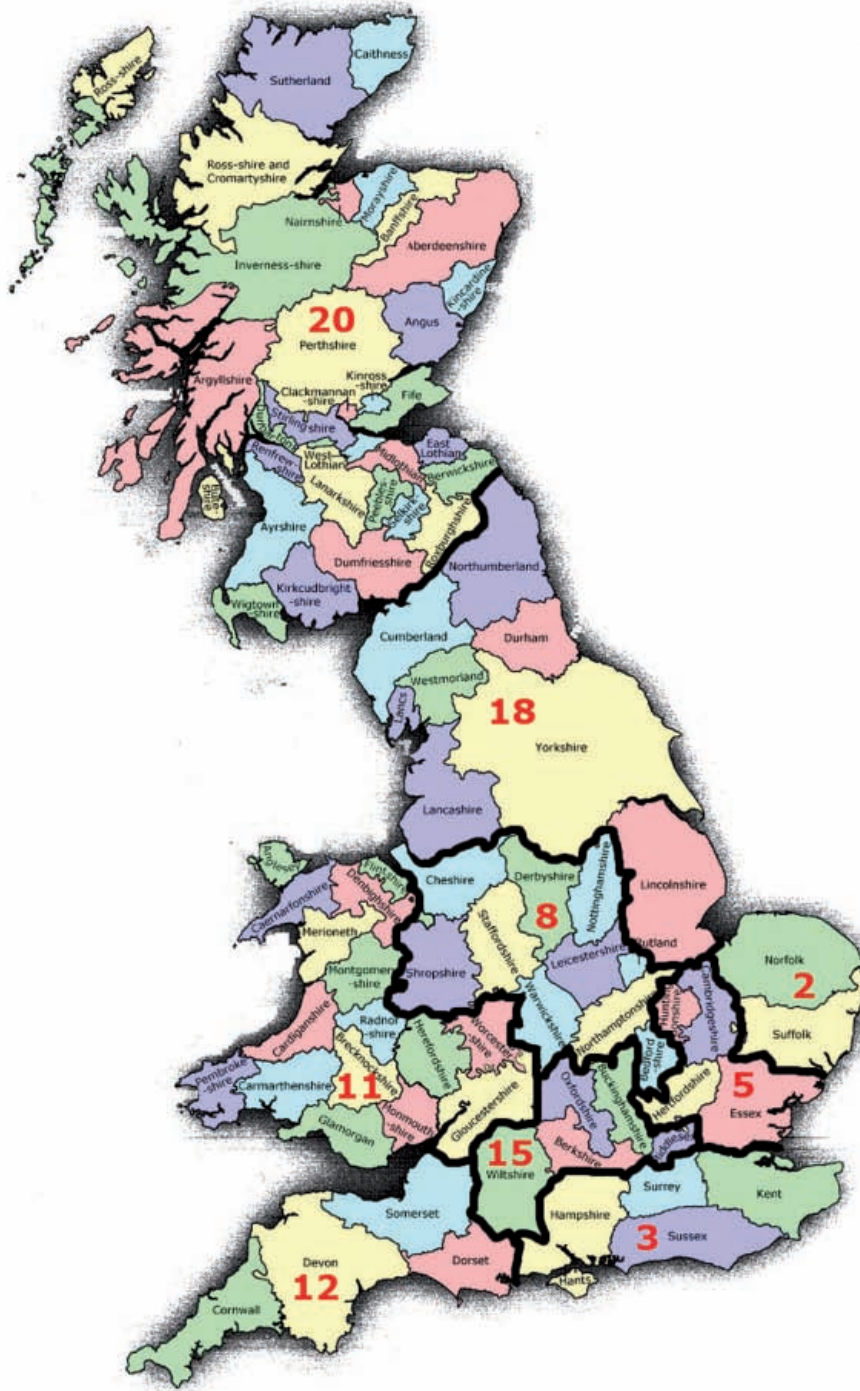

Fig. 20





Area 20 - John Cunningham
07771 666673

Area 18 - David Brook
07973 702425

Area 8 - Tim Stilgoe
07879 474040

Area 11 - David Higgins
07836 681284

Area 2 - Andrew Wilding
07788 583339

Area 5 - John Hammond
07887 838165

Area 15 - Phil Lowe
07525 909049

Area 3 - Ross Bridges
07720 940686

Area 12 - Frank Ewer
07590 443086

National Sales Manager
Richard Hiblen
07787 557570

Specflue Training Centre

Specflue place a large importance on education and training to the trade and our customers in general. Several years ago we invested in a new building allowing us some much needed training space. Because of this we are now able to offer HETAS training courses hosting 12 courses in 2010 all subsidised by Specflue.

With the increased demand in our field we are now embarking on phase 3 of our training programme. Early 2010 we are increasing the size of our current training centre to encompass a holistic view of the trade. This will include appliances – working flues – working roof's and floors – fireplaces and biomass products and regulations.

Practical training within the trade is poor at best and Specflue are working to remedy this. We will have on-site practical assessors enabling us to run HETAS conversion courses for existing gas and oil installers and full working heating systems giving complete training skills on both wet and dry appliances and flues.

So whether you are looking to join this growing trade – or simply brush up on your technical knowledge – Specflue want to help you achieve your goals. The use of the training centre will be free of charge to all our customers, except for external trainer charges, and we look forward to working closely with them ensuring a safe and professional industry moves forward for future years.